

Product Specification

Name: High voltage LCD display DMX controller with short circuit protection
Model: DMX300C



1. Summarization

High-voltage DMX controller with LCD display is a kind of controller with LCD digital display interface, used for control the RGB color change of 5 line 4 channels(common anode) LED lamps, up to 34kinds of change programs to choose, at the same time can accept DMX-512 international standard digital control. Controller can be stand-alone operation, automatically online, accept standard DMX512 console control signal etc. method to work. According to the customer's actual demand, can achieve jumpy changing, gradual changing, stroboscopic such change effect.

2. Technical Parameters

Working temperature: -20-60°C

Power supply voltage: AC 100~240V 50/60HZ

Output voltage: DC 100~240V

Output connect way: common anode 5 line 4 channels

External dimension: L205*W103*H40 mm

Packing size: L225*W120*H55 mm

Net weight: 698.5g

Gross weight: 900g

Static power consumption: <2W

Maximum output current: 4*2A, each circuit has short-circuit protection function and 20% fuse protection for overload.

Dimming frequency: 980Hz

Maximum output power: 880W (input voltage: 110V) , 1760W (input voltage: 220V)

3. External Dimension

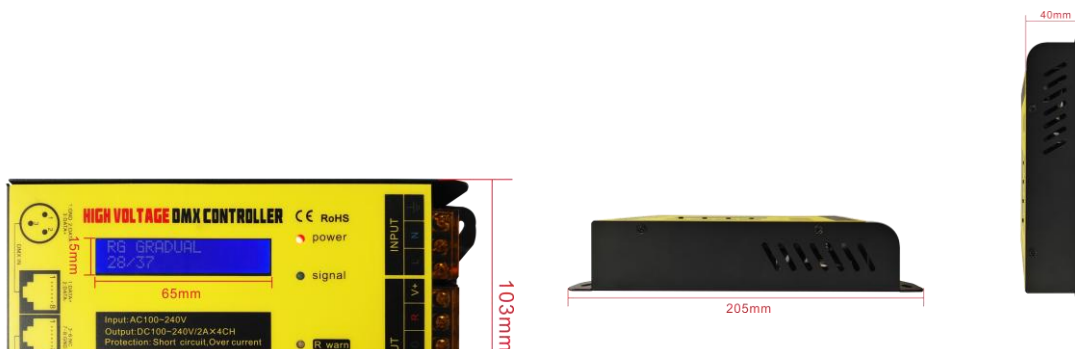

terface instruction:



1.Power supply interface: input AC100~240V, 50Hz/60Hz

- L——Live line
- N——Neutral line
- ≡——PE, Earth line

Load output interface: load output,

- V+——Load common positive pole
- R——Load red output pole
- G——Load green output pole
- B——Load blue output pole
- W——Load white output pole

2.DMX512 signal input/output interface: the interface sequence and details are shown in below picture:



3.Indicator light description

- (1) **power** : The power indicator, which is always red, indicates that the controller's working voltage is normal;
- (2) **signal** : Signal indicator light, green, when there is button operation or external DMX control, the indicator light flashes;
- (3) **R warn** : R channel fault light. When the red indicator light is on, it means that the R channel load is faulty (short circuit or overload). It is necessary to turn off the power to remove the fault. After the fault is removed, turn on the power again. The red indicator light is off, indicating that the R channel is normal.
- (4) **G warn** : G channel fault light, when the red indicator light is on, it means that the G channel load is faulty (short circuit or overload), and the power needs to be turned off to remove the fault. After the fault is removed, turn on the power again. The red indicator light is off, indicating that the R channel is normal.
- (5) **B warn** : Channel B fault light. When the red indicator light is on, it means that the B channel load is faulty (short circuit or overload), and the power needs to be turned off to remove the fault. After the fault is removed, the power is turned on again. The red indicator light is off, indicating that the B channel is normal.
- (6) **W warn** :W channel fault light, when the red indicator light is on, it means that the W channel load is faulty (short circuit or overload), and the power needs to be turned off to remove the fault. After the fault is removed, the power is turned on again. The red indicator light is off, indicating that the W channel is normal.

4. Description of overload protection

The maximum output current of each channel of the controller is 2A. When the load exceeds 20% of the maximum current, it will damage the electronic devices and reduce the use time of the controller. When the controller cannot work normally due to overload, please reduce the load, check the fuse, if the fuse is burned out, replace the fuse, and then power on again after troubleshooting.

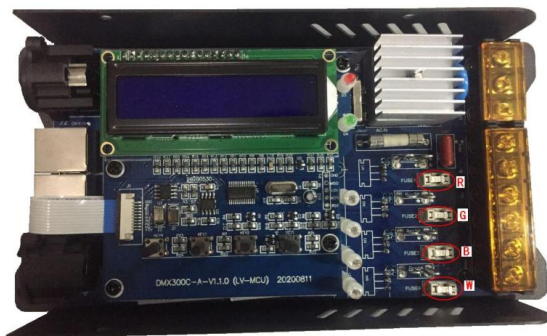

The red circle is the fuse of the corresponding channel

5. Direction for use

1. Connect the load wire at first, following by the power wire; Please ensure short circuit can not occur between connecting wire before you turn on the power.

Controller have 4 function setting key: MODE, PARA, UP, DOWN.

2. MODE key choose in turn or press UP, DOWN key to choose:

No.	Display content	Instruction
1	BLACK	Static black
2	STATIC RED	Static red
3	STATIC GREEN	Static green
4	STATIC BLUE	Static blue
5	STATIC YELLOW	Static yellow
6	STATIC PURPLE	Static purple
7	STATIC CYAN	Static cyan
8	STATIC WHITE	Static white (RGB)
8-2	STATIC WHITE	Static white (W)
9	COLOR CHANGE	Seven color jumpy changing
10	COLOR CHANGE2	Jumpy changing (flicker)
11	6 COLOR CHANGE	Six color jumpy changing
12	6 COLOR CHANGE2	Jumpy changing (flicker)
13	RGB CHANGE	Three color jumpy changing
14	RGB CHANGE2	Jumpy changing (flicker)
15	RG CHANGE	RG jumpy changing
16	RB CHANGE	RB jumpy changing
17	GB CHANGE	GB jumpy changing
18	WHITE CHANGE	White stroboflash
19	7 COLOR SMOOTH	Seven color gradual changing
20	4 COLOR SMOOTH	Four color gradual changing
21	RG SMOOTH	RG gradual changing
22	RB SMOOTH	RB gradual changing
23	GB SMOOTH	GB gradual changing
24	COLOR GRADUAL	Seven color fade in and out
25	RGB GRADUAL	Three color fade in and out
26	WHITE GRADUAL	White fade in and out
27	YELLOW GRADUAL	yellow fade in and out
28	PURPLE GRADUAL	purple fade in and out
29	CYAN GRADUAL	cyan fade in and out
30	R GRADUAL	R fade in and out
31	G GRADUAL	G fade in and out
32	B GRADUAL	B fade in and out
33	ADJUST MODE	RGBW 0-255 level color adjustable
34	AUTO PROGRAM COLOR CHANGE2	Auto operation selecting result of changing
35	DMX512 MODE	DMX512 control order

36	DMX512 DECODER	DMX512 decoder
----	----------------	----------------

3. Press PARA to adjust in turn: (1—8 is static state, do not have adjust function)

No.	Parameters display	Instruction	
		Maximum	Minimum
1	RUN SPEED	100	0
2	RUN TIMES	100	0
3	LOAD DEFAULT	Restore the factory parameter	

4. UP: increase parameter key/preset parameter.

5. DOWN: decrease parameter/preset parameter.

6. AUTO PROGRAM mode is repeatedly cycle running part or all of 7-32 patterns run, you can set whether participating in repeated cycle of operation or not in RUN TIMES.

7. RUN TIMES: compiling the run times of the pattern under 34 AUTO PROGRAM, if the run times is 0, you can skip the pattern, that means not running the pattern.

8. Preset parameter: each form has independent factory preset parameter, which is kept in controller separate. LOAD DEFAULT can recover the factory parameter of the form. If under AUTO PROGRAM mode, using LOAD DEFAULT can unified recover the parameter of all forms to factory parameter.

9. 32 ADJUST MODE is manual dimming, it can adjust the brightness of RGB 0-256 level respectively.

10. 34 DMX512 MODE is controlling all patterns (the first address) and speed (the second address).

11. 35 DMX512 DECODER is DMX decoder, completely accepting outside DMX512 signal to work. Taking 4 addresses, R(the first address), G(the second address), B(the third address), reserved channel(the fourth channel), in need of setting address (by pressing PARA).

6. Typical Application

Typical application 1---without DMX function:



Typical application 2---with DMX function:

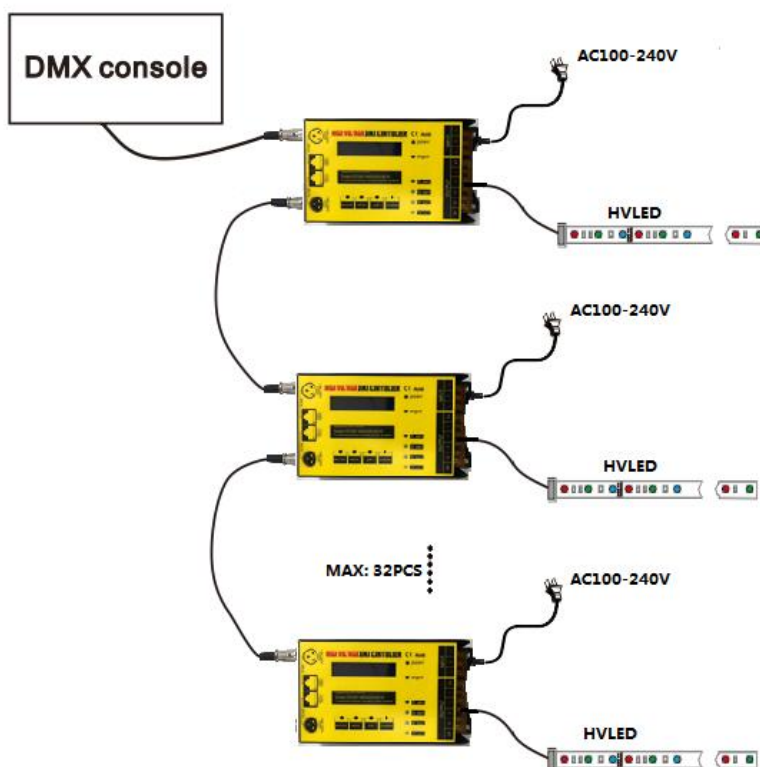

7. Remarks

1. Connect the load wire at first, following by the power wire; Please ensure short circuit can not occur between connecting wire before you turn on the power;
2. Power supply voltage range is AC90-240V, more than voltage range maybe burn out the controller.